

PROFIBUS ABSOLUTE MULTI-TURN ENCODER, MHK515-PROF RANGE

- MHK15-PROF, standard encoder Ø58mm with Profibus interface:
- Robust and compact conception
- Solid shaft version Ø 10 mm (06 mm available upon request)
- Precision ball bearings with sealing joint
- High temperatures performances -40°C ... +85°C
- Code disc made of unbreakable and durable plastic
- Mechanical memorization of the number of turns by gears
- Resolution : 13 bits = 8192 steps/turn (max 16 bits)
- Number of turns : 12 bits = 4096 turns (max 14 bits)
- Polarity inversion and short circuit protection
- Highly integrated circuit in SMD-technology

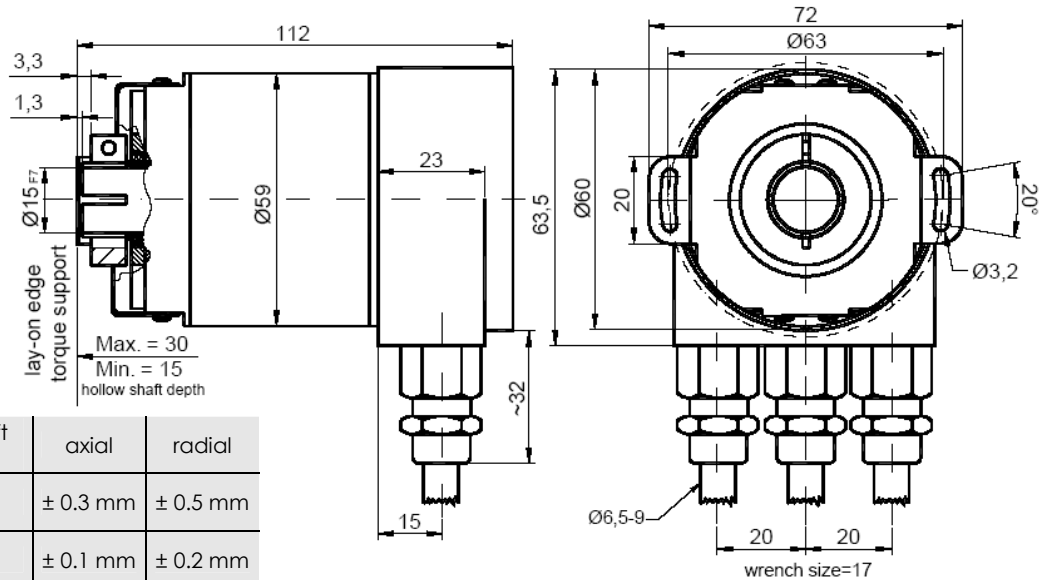

MHK515-PROF (connection cap included)



Allowed shaft movements	axial	radial
static	± 0.3 mm	± 0.5 mm
dynamic	± 0.1 mm	± 0.2 mm

Shaft diameter can be reduced at 12mm, 10mm or 8mm by reduction ring (by inserting them into the hollow shaft)

Red LED	Green LED	Status / possible cause
Dark	Dark	No power supply
Bright	Bright	Encoder is ready for operation but it has not received any configuration data after power on. Possible causes: address setting incorrect, Bus lines not connected correctly
Bright	Flashing	Parameter or configuration error. The encoder receives configuration or parameter data with incorrect length or inconsistent data Possible cause: parameter value "total measuring range" too high
Flashing	Bright	The encoder is ready for operation but not addressed by the master (e.g. incorrect address in configuration).
Bright	Dark	Encoder has not received any data for a longer period (about 40 sec.) Possible cause: bus line has been interrupted
Dark	Bright	Normal operation in data exchange mode
Dark	Flashing	Commissioning mode

Led status at the front of the connection cap

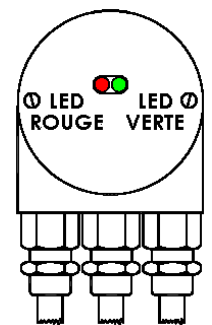

MECHANICAL DATA

Material (option stainless steel)	Cover : aluminum	Shocks (EN 60068-2-27)	≤ 100 g (half sine, 6 ms)
	Body : aluminium	Perm. shocks(EN 60028-2-29)	≤ 10 g (half sine, 16ms)
	Shaft: Stainless steel	Vibration (EN 60068-2-6)	≤ 10 g (10Hz... 1 000Hz)
Max. shaft loading	Axial : 40 N	Weight (Aluminium Version)	600 g
	Radial : 110 N	Operating temperature	- 40 ... + 85°C
Shaft Inertia	≤ 30 g.cm ²	Storage temperature	- 40 ... + 85°C
Torque	≤ 3 N.cm	Humidity	98 % without condensation
Speed (continuous)	6 000 RPM	Protection (EN 60529)	Cover: IP65, Shaft: IP64



Tel : +33 (0)3 88 02 09 02 / Fax : +33 (0)3 88 02 09 03 / E-mail : info@ak-industries.com / Web : http://www.ak-industries.com

PROFIBUS ABSOLUTE MULTI-TURN ENCODER, MHK515-PROF RANGE

ELECTRICAL DATA

Interface	ISO 11898	Power consumption	max 2,5W
Transmission rate	Max 12 MBauds	Step Frequency LSB	800 kHz
Device addressing	by rotary switches	Accuracy	+ 1/2 LSB
Power supply	10 – 30Vdc	EMC	EN 61000-6-4 EN 61000-6-2
Current consumption	max 100mA (24Vdc)	Electrical lifetime	> 10 ⁵ h

PROGRAMMABLE PARAMETERS

The Profibus-DP interface supports CLASS 1 and CLASS 2 functionality according to the encoder profile . In addition to these functions the GSD-file supports further features, for example software limit switches. Further more, the following encoder parameters can be programmed directly via the Profibus-DP network without any extra device

Counting Direction	This parameter counting direction defines whether the output code increases or decreases when the shaft rotates clockwise.
Resolution (positions per turns)	The parameter 'resolution per revolution' is used to program the desired number of steps per revolution. Each value between 1 and the physical resolution per revolution can be programmed
Total Resolution "Max-RANGE"	This parameter is used to program the desired number of measuring units over the total measuring range. This value may not exceed the total physical resolution of the absolute rotary encoder
Reset (RAX)	The preset value is the desired position value, which should be reached at a certain physical position of the axis. The position value is set to the desired process value by the parameter preset
Velocity	The implemented software can additionally deliver the current velocity. This value is transmitted in binary code, 16 Bit, in addition to the process value It is possible to choose between four different units: steps per 10 ms, per 100 ms, per 1000 ms and revolutions per minute
Software limit switches function	Two software limit switches can be set. If the position value falls below the lower or exceeds the higher limit switch, a status bit in the process value is set
Teach-in (Online parameterization)	A special mode is available for commissioning phase of the device. This makes it possible to change parameters while the encoder is in data exchange mode

INTERFACE

The rotary encoder is connected by two or three cables, depending on whether the power supply is integrated into the bus cable or connected separately. If the power supply is integrated into the bus cable one of the cable glands can be fitted with a plug. The cable glands are suitable for cable diameters from 6,5 up to 9 mm

The Profibus-DP device address is set by user-friendly rotary switches in the connection cap. Allowed addresses are between 1 and 99, each can only be used once. The connection cap can easily be opened for installation by removing the two cap screws

Termination resistors are integrated in the connection cap. These must be switched on if the encoder is connected at the end or the beginning of the bus

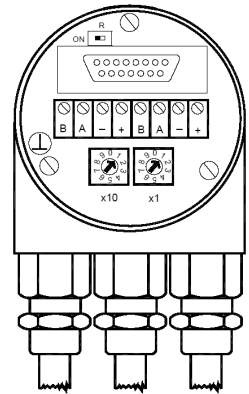

ORDERING REFERENCE Contact the factory for special versions, ex: electronics, special flanges, connections...)

MHK5	DP	B1	B	12	13	B	15	0	0CC
Absolute multi turn encoder	Profibus	Version	Code : Binary	Number of turns 2 ¹² (4 096)	Resolution (pos./turn) 2 ¹³ (8 192)	Clamp Flange	Shat diameter : 15mm	Without mechanical option	Connection Cap

Ordering code : MHK515-PROF-001 = MHK5 - DP B1 B - 12 13 - B 15 0 - 0CC

