

# DEVICE NET ABSOLUTE MULTI-TURN ENCODER, MHM510-DNET RANGE

- MHM510-DEVICE NET, standard encoder Ø58mm with DeviceNet interface:
- Robust and compact design
- Solid shaft version Ø 10 mm (06 mm available upon request)
- Precision ball bearings with sealing flange
- High temperatures performances -40°C ... +85°C
- Code disc made of unbreakable and durable plastic
- Mechanical memorisation of the number of turns by gears
- Resolution : 13 bits = 8192 steps/turn (max 16 bits)
- Number of turns : 12 bits = 4096 turns (max 14 bits)
- Polarity inversion and short circuit protection
- Highly integrated circuit in SMD-technology

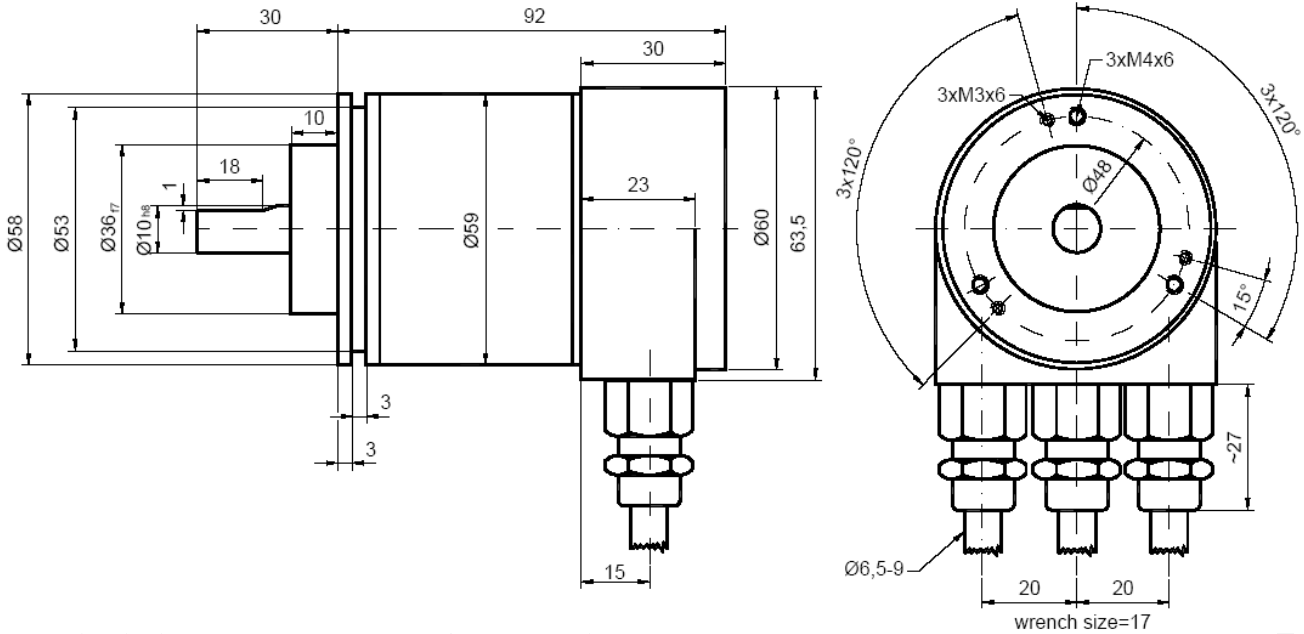

**MHM510-DNET (connection cap included)**



Status visualization by 2 LED's at the back of the connection cap

Err - Green LED	Sta - Green LED	Meaning
off	off	No power supply
off	on	Encoder is ready, Boot Up message not sent (no further device on network, wrong baud rate) or encoder in prepared status
flashing	on	Boot Up message sent, device configuration is possible
on	on	Normal operation mode, Encoder in Operational Status

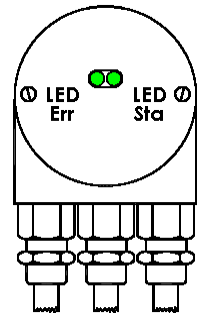

## MECHANICAL DATA

Material	Cover : aluminum	Vibrations (EN 60068-2-6)	≤ 10 g (10Hz... 1 000Hz)	
	Body : aluminum	Weight	600 g	
	Shaft: stainless steel	Operating temperature	- 40 ... + 85°C	
Max. shaft loading	Axial : 40 N	Storage temperature	- 40 ... + 85°C	
	Radial : 110 N	Humidity	98 % without condensation	
Shaft Inertia	≤ 30 g.cm <sup>2</sup>	Protection class (EN 60529)	IP65: cover	
Torque	≤ 3 N.cm		IP64: flange	
RPM (continuous operation))	6 000 tr/min	Lifetime in 10 <sup>8</sup> revolutions with F <sub>a</sub> / F <sub>r</sub> (axial / radial)		
Shock (EN 60068-2-27))	≤ 100 g (halfsinus, 6 ms)	40 N / 60 N	40 N / 80 N	40 N / 110 N
Shock (EN 60028-2-29)	≤ 10 g (half-sinus, 16ms)	25	10	4



Tel : +33 (0)3 88 02 09 02 / Fax : +33 (0)3 88 02 09 03 / E-mail : info@ak-industries.com / Web : http://www.ak-industries.com

# DEVICE NET ABSOLUTE MULTI-TURN ENCODER, MHM510-DNET RANGE

## ELECTRICAL DATA

Interface	Transceiver according ISO/DIS 11898	Power consumption	max 2,5W
Transmission rate	Max 500KBauds	Step frequency LSB	800 kHz
Device addressing	By rotary switches	Accuracy of division	+ 1/2 LSB
Power Supply	10 – 30Vdc	EMC	EN 61000-6-4 EN 61000-6-2
Current consumption	max. 100mA (24Vdc)	Electrical lifetime	> 10 <sup>5</sup> h

## TRANSMISSION MODE

Polled Mode	By a telegram the connected host calls for the current process value. The absolute rotary encoder reads the current position value, calculates eventually set-parameters and sends back the obtained process value by the same identifier
Change of State	The absolute rotary encoder transmits the actual process value. The process value is transmitted when the position changes. This is useful to reduce the bus activity
CYCLIC Mode	The absolute rotary encoder transmits the actual process value event controlled by an internal timer. This is also useful to reduce the bus activity

## PROGRAMMABLES PARAMETRES

Operating Parameters	As operating parameters the code sequence (complement) can be programmed. This parameter determines the counting direction, in which the output code increases or decreases
Resolution (pos./turn)	The parameter resolution per revolution is used to program the desired number of steps per revolution. Value between 1 and 8 192 can be programmed
Total Resolution "Max-RANGE"	This parameter is used to program the desired number of measuring units over the total measuring range. This value may not exceed the total resolution of the absolute rotary encoder. If the encoder is used in a continuous measuring application, certain rules for the setting of this parameter must be followed. These rules are outlined in the manual
Preset Value	The preset value is the desired position value, which should be reached at a certain physical position of the axis. The position value is set to the desired process value by the parameter pre-set

## INSTALLATION

The rotary encoder is connected by three cables. The power supply is achieved with a two-wire connection cable through one PG 9. Each one of the twisted-pair and shielded bus lines are guided in and out through two PG 9 on the right side (as seen on clamps)

## CONFIGURATION

The setting of the node number is achieved by 2 turn-switches in the connection cap. Possible addresses lie between 0 and 63 whereby every address can only be used once. 2 LEDs on the backside of the connection cap show the operating status of the encoder

There is a resistor provided in the connection cap, which must be used as a line termination on the last device

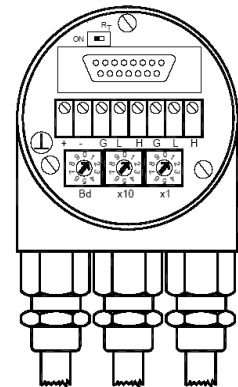

## ORDERING REFERENCE (Contact the factory for special versions, ex: electronics, special flanges, connections...)

MHM5	D2	B1	B	12	13	C	10	0	0CC
Absolute multi turn encoder	DEVICE NET	Version	Code : Binary	Number of turns 2 <sup>12</sup> (4 096)	Resolution : 2 <sup>13</sup> (8 192)	Clamp flange	Shaft diameter : 10mm	Without mechanical option	Connection Cap

Ordering code: **MHM510-DNET-001** = MHM5 - D2 B1 B – 12 13 - C10 0 - 0CC



Tel : +33 (0)3 88 02 09 02 / Fax : +33 (0)3 88 02 09 03 / E-mail : [info@ak-industries.com](mailto:info@ak-industries.com) / Web : <http://www.ak-industries.com>