

PHU9, the new generation of CANopen absolute multi-turn encoders :

- 90mm encoder, extra-flat,
- Ø30mm through shaft version, reduction hubs available,
- Robustness and excellent resistance to shocks / vibrations,
- High protection level IP65,
- High performances in temperature -20°C to 85°C,
- Universal power supply from 5 to 30 Vdc,
- High resolutions up to 8192 points per turn (2¹³),
- Turns numerisation up to 65 536 (16 bits).

CANopen

DS 301 V4.02

DS 406 V3.1



PHU9_25 connection BCR (radial M23), with reduction hub 9418/I25 (25mm) mounted on the shaft

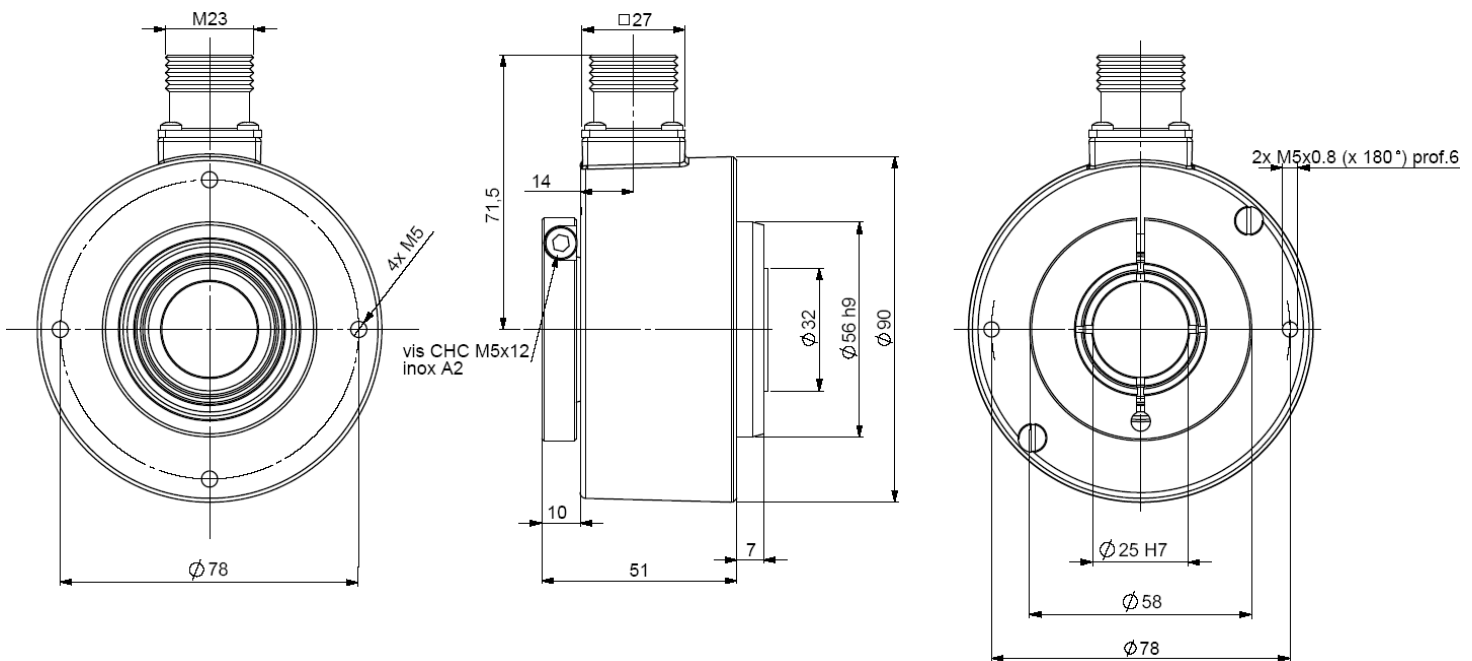

MECHANICAL CHARACTERISTICS

Material	Cover : steel	Shocks (EN60068-2-27)	≤ 500 m.s ⁻² (during 6 ms)
	Body : aluminium	Vibrations (EN60068-2-6)	≤ 100 m.s ⁻² (10 ... 2 000 Hz)
	Shaft : stainless steel	EMC	EN 61000-6-4, EN 61000-6-2
Bearings	6 807 serial	Isolation	100V (1 min)
Maximum loads	Axial : 50 N	Encoder weight (approx)	0,700 kg
	Radial : 80 N	Operating temperature	- 20... + 80 °C (encoder T°)
Shaft inertia	≤ 55.10 ⁻⁶ kg.m ²	Storage temperature	- 20... + 80 °C
Torque	≤ 25.10 ⁻³ N.m	Protection(EN 60529)	IP 65
Permissible max. speed	6 000 min ⁻¹	Torque (ring pressure screw)	nominal: 3N.m, break: 4N.m
Continuous max. speed	3 600 min ⁻¹	Theoretical mechanical lifetime 10 ⁹ turns (F _{axial} / F _{radial})	
Shaft seal	Viton	25 N / 40 N : 140	50 N / 80 N : 17



ELECTRICAL CHARACTERISTICS

Power supply	5 – 30Vdc
Introduction	< 1 s
Consumption (without load)	< 50mA (at 24Vdc)
Accuracy	± ½ LSB (13 bits)

Programmable parameters

Resolution: defines the resolution per revolution (0 to 8 192),

Global resolution : total amount of codes for the encoder (2 to 536 870 912),

Transmission speed : programmable from 10kbaud (1000m) to 1 Mbaud (40 m) ; value per default: 20 Kbaud,

Address: define the software address of the encoder on the bus (1 to 127, value by default: id = 1),

Direction : define the direction of count of the encoder ,

RAX : defines the value of its preset position (non turning shaft),

CAM: Low and High Limits.

Communication modes

3 modes are available to interrogate the encoder :

POLLING mode: (Response to a RTR message): The position value is only given upon request (SDO mode),

CYCLIC mode: the encoder transmits its position in an asynchronous manner. The frequency of the transmission is defined by the programmable cyclical timer register from 0 to 65 535 ms,

SYNCHRO mode: the encoder transmits its position on a synchronous demand by the master.

CANOPEN CONNECTION

1	2	3	4	5	6	7	8, 9, 11	10	12
Reserved	CAN LOW	CAN GND	Reserved	Reserved	Reserved	CAN HIGH	Reserved	0V	+ 5/30Vdc

Pinout 3 (CAN GND) and 10 (0V) are connected together (intern the encoder).

Nota : Refer to the bus standards for the maximal derivation length.

ORDERING CODE (Special versions upon request, for ex. special flanges/electronics/connections...)

	Shaft Ø	Power supply	Output stages	Code	Resolution	Nb of turns	Connection	Connection orientation
PHU9	30 : 30mm Reduction hubs available	P : 5 to 30Vdc	BB : CANopen	B : Binary	13 : 8192 points per turn (2 ¹³)	B16 : 65 536 turns (2 ¹⁶)	BC: M23 12 pinouts clockwise	R : radial
PHU9 _	30 //	P	BB	B //	13	B16 //	BC	R