

Accessories

Clearance compensation angle

Ref : ERJ40-002

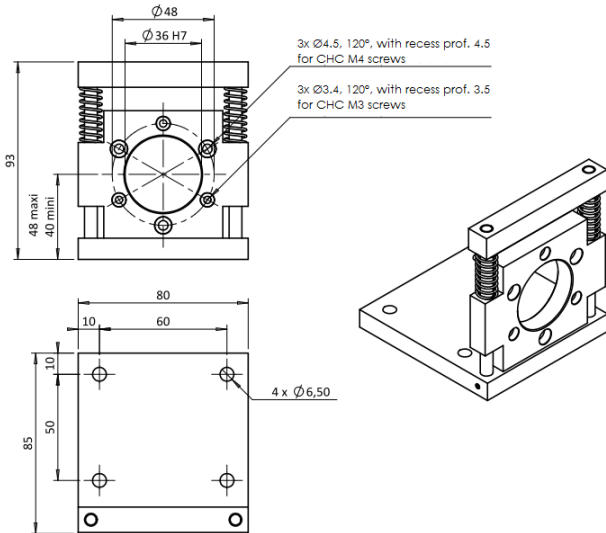

Fixation angle

Ref : EF058-001

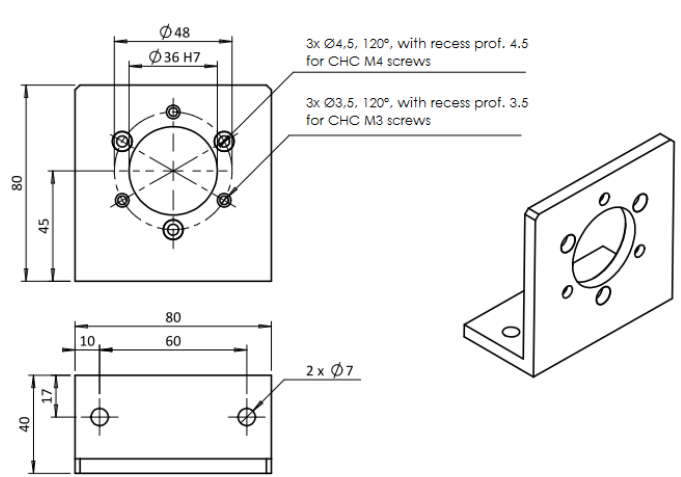

Measuring wheel

Ref : RM200-001

Perimeter 200mm
(Ø63.60)

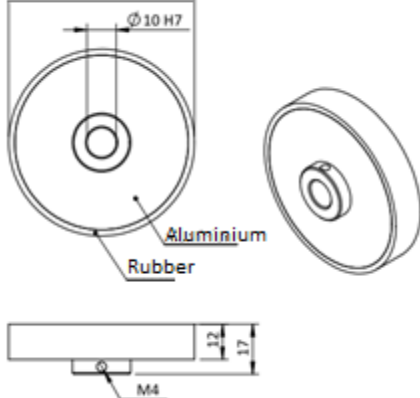

Oldham coupling

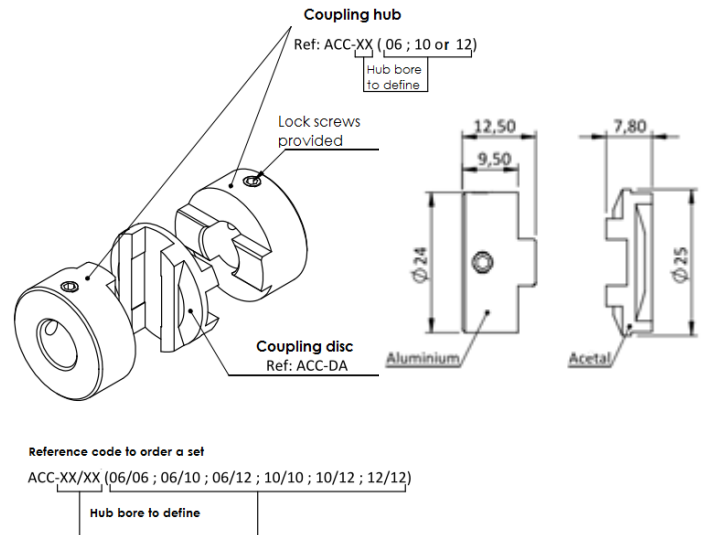

Cylindrical eccentric (to mount angular sensors and optical encoders)

Provided with a set of 4 eccentrics + 4 screws

Ref : EXC-001

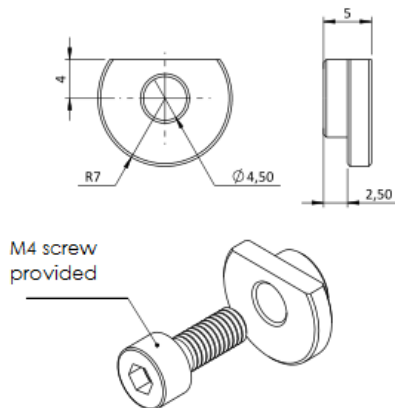

Ref : EXC-002

